



Equipment Supply Company



Instruction Manual

YAK 44/22 Ton Jack

ESCO #92002



FOREWORD.....	3
SAFETY REGULATIONS	3
PACKING	4
PUTTING INTO OPERATION	4
USE	5
WARRANTY	5
MAINTENANCE JOBS FOR THE END USER	5
MAINTENANCE RESERVED TO A PROFESSIONALLY QUALIFIED ENGINEER	6
TECHNICAL DATA SHEET.....	8
DRAWINGS	9
TROUBLESHOOTING.....	11
REQUESTING SPARE PARTS	13

	<i>DANGER!</i> <i>BE PARTICULARLY CAREFUL</i>
	<i>CRUSHING DANGER</i>
	<i>MANDATORY. OPERATIONS OR JOBS TO BE PERFORMED COMPULSORILY</i>
	<i>FORBIDDEN!</i>

FOREWORD

Dear Customer, before using the jack, carefully read these instructions and become acquainted with the safety symbols.

- This handbook is an integral part of the machine which must be kept safely and be handy for the worker to consult whenever needed.
- The contents of this manual comply with Machine Directive 2006/42/CE and the jack is type approved in conformity with the European Norm EN 1494 and following amendments.
- The manufacturing company reserves the right to make modifications without prior notice and without incurring any sanctions whatsoever, without prejudice to the safety and main technical characteristics.
- Failure to observe the instructions may cause personal injury, which in some cases may be mortal.
- The manufacturer is not liable for any damage to things or injury to people caused by an erroneous or incorrect use of its product. The identification plate is on the side of the casing. **DWG. 1**

SAFETY REGULATIONS

- Only authorised personnel are allowed to use the equipment and they must know the contents of this operating and maintenance handbook.



- The jack is an apparatus for lifting only and not for supporting, it is therefore absolutely forbidden to work in any way under the vehicle being lifted until it is placed on the relative stands. **DWG. 2**

- Before starting to lift a vehicle it has to be blocked with the parking brake and/or by putting wedges under the wheels, as illustrated in figure **DWG. 3**

- If the vehicle is loaded check load stability when lifting.

- Place the jack so that the load is centred over it and where the gripping points are indicated by the vehicle manufacturer.

DWG. 4

- During lifting and lowering, it is necessary to check there are no persons or animals under the suspended load or in the vicinity.

- Before lowering the load make certain the handle is in the horizontal position. **DWG. 5**



- Never lift loads on sloping, uneven or soft ground. **DWG. 6**

- If extensions are needed use only those supplied by the manufacturer with the jack.

Do not use extensions without the relevant plate. Never use more than two extensions. **DWG. 7**

- Do not lift the load in a confined space so as not to run the risk of getting trapped.

- It is forbidden to use more than one jack simultaneously on the same load.

- Never tamper with the pressure relief valve that has the guarantee seal. **DWG. 8**

- Do not leave any pressure in the pistons at end of stroke when there is no load

PACKING

- The body, handle and other parts of the jack are packed in a three-layer corrugated cardboard box; the operating and maintenance manual plus the warranty certificate in a folder are also inside the box.
- The instruction "Keep upright" is clearly visible on the cardboard box containing the jack.
- Depending on the number of jacks shipped, pallets of different sizes are used.
- Either transpallets or forklift-trucks are used for handling.

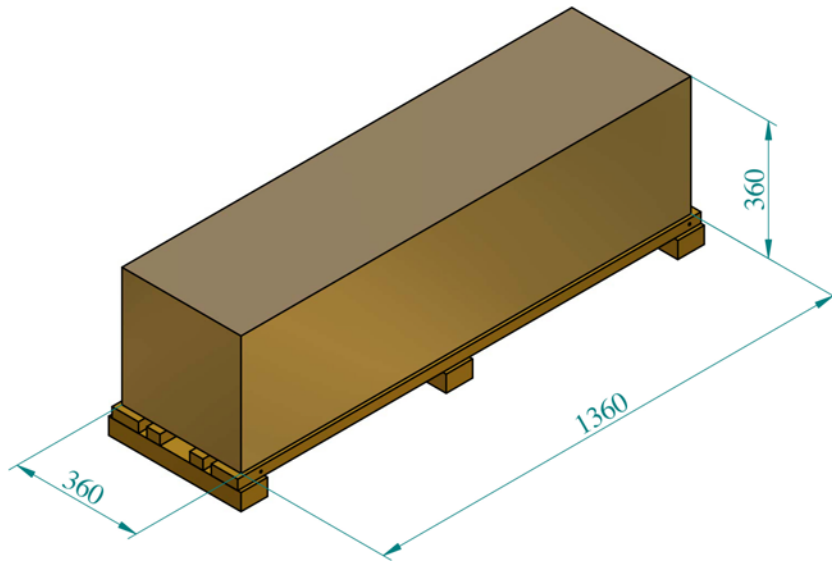

PUTTING INTO OPERATION

ASSEMBLY

1. Take the handle, the jack and the extensions out of the cardboard box.
2. The handle is divided into three parts. Prior to use, assemble as shown in the drawing using the dowel and spanner supplied. **DWG. 10**

CONNECTION TO THE COMPRESSED AIR SYSTEM

- Compressed air enters into the jack circuit through the quick coupling on the top of the manual lifting/descending controls; it is therefore necessary to have a connecting pipe with a quick coupling compatible with that of the jack. Check that the air supply pipe has a useful passage of at least 6 mm and it is not pinched or restricted anywhere. **DWG. 11**

WORKING AIR PRESSURE: 116 - 145 PSI

- Absolutely never put the following into the compressed air circuit: hydraulic or Vaseline oil, brake liquid, kerosene or other liquids.
- Install a filter dehumidifier-lubricator unit in the compressed air system.
- If you want to lubricate the compressed air circuit use exclusively:

ACCESSORIES

The jack is supplied with two extensions or height adapters (60mm extensions), and a circular tooth plate (16mm plate).



Never use more than two extensions! The manufacturer is not liable for any damage resulting as a consequence of disregard for the above indications and the warranty conditions are invalidated thereof!

SCRAPPING AND DISPOSAL

- The lubricants must be disposed of in compliance with the anti-pollution laws in force.
- Scrapping the jack and its component parts must be carried out by the user in accordance with current laws.

USE

- Expressly observe the safety rules already described in this manual.



1) Position the jack under the supports as described in the manual of the vehicle the manufacturing company is not responsible for any break or damage to the lifted vehicle or to persons or property due to an incorrect use of the jack.

2. By pressing key A on the control block the lifting function is activated. **DWG. 12**

3. By pressing key B on the control block the lowering function is activated. **DWG. 12** In the absence of any load, the pistons do not drop completely. Lower them manually to complete the descent.

4. After lifting the load, it is absolutely essential to rest it on the support stands before doing any work under it.



REMEMBER THAT THE JACK IS A LIFTING DEVICE AND NOT A SUPPORTING DEVICE!!

- The operator's employer will have to provide the necessary training and furnish the necessary information about the pumping and shifting forces.

- **Before working with the jack, it is advisable to perform a few operations with no load in order to acquire the sensitivity necessary to work safely with the jack.**

- When the jack is not used, always keep the pistons lowered

IMPROPER USE

The air-hydraulic jack has been designed and made to lift transport vehicles. Any other use of the jack, such as for instance lifting and/or moving persons, is considered to be definitely improper. All use of the jack not in conformity with the safety rules listed in this manual is considered to be improper use.

WARRANTY

This jack is covered by a 12-month warranty starting from the date the jack leaves our factory if it has not been extended on-line; it covers all manufacturing defects but not transport expenses, defects caused by improper use or damages suffered during transport. For more details please see the card attached to this manual.

MAINTENANCE JOBS FOR THE END USER

- To ensure your jack a long life it is advisable to clean the pistons externally once a fortnight.
- Check the level of oil in the tank at least twice a year.

CHECK THE OIL LEVEL

IMPORTANT: the maximum quantity of oil in this jack is 1.2 L. Compatible oil: ATF DEXRON IID

Please follow the steps listed here to check the oil level:

1. Bleed off the air (see procedure in the next section)
2. Loosen the screw POS. 7 - **A00388** and then the screw POS. 8 - **A00388** (see **DWG 13**)

3. If the oil fails to come out POS. 8 - A00388 once the screw has been loosened, the level is too low. In this case, add oil. The level must be at the height of screw POS. 8 - A00388.
4. If oil does come out, let the excess quantity drain off until the right level is reached (see point 4).
5. Re-tighten the screw POS. 8 - A00388. Operate the lifting control and allow the pistons to move up by about 4 cm, then re-tighten the screw POS. 7 - A00388

AIR BLEEDING

Each time the jack is serviced, removing and refitting parts connected to the tank and motorpump, it is advisable to bleed off all air. Bleeding phases:

1. The pistons must be moved out completely.
2. Loosen the dowel POS. 9 exploded drawing A00388 inside the piston POS. 2 - A00388
3. Let all the air flows out of the dowel until the oil starts to come out. If necessary, push the piston downwards and then close the dowel again.
5. Let all the air out from the dowel and continue until oil starts coming through and then close the dowel.
8. Move the pistons back in completely and check oil level.
9. Try to operate the jack without any load and if the piston lowers in jerks repeat the procedure at least 2 or 3 times.

MAINTENANCE RESERVED TO A PROFESSIONALLY QUALIFIED ENGINEER

Having to carry out maintenance or overhauling, use exclusively genuine spare parts to ensure the utmost reliability for the jack.

PROBLEMS

Solutions

THE MOTOR WILL NOT START, OR IT RUNS BADLY.

- Check that the air supply line is not choked.
- If the pistons fail to move up, the pump could be empty. Completely lower the pistons by means of the descent control and subsequently pressing with your hand, once the pistons have been lowered, press the up and down commands a few times alternately. This will enable the pump to recharge.
- If the pistons are already completely lowered and the lifting command is not working, the pump will have to be recharged according to the following procedure:
 1. Connect the jack to the compressed-air circuit
 2. Loosen the screw POS. 7 - A00388
 3. In place of the screw just removed, screw on a pipe with compatible coupling.
 4. Blow a small quantity of air inside the tank through the pipe just fitted and, at the same time, operate the lifting command.
 5. If, when the lifting command is operated, the pistons also move up without blowing air into the tank, the pump has recharged and you can proceed to the next step. Otherwise, repeat the operations illustrated at the previous point.
 6. Allow the pistons to move completely up by operating the lifting command. If the pistons move in jerks, the bleeding procedure will have to be performed (see "Maintenance reserved to the end user").
 7. Let the pistons re-enter being careful to leave the large piston POS. 3 - A00388 out by 4 cm.
 8. Remove the pipe fitted at point (3), and re-tighten the screw POS. 7 - A00388
 9. Fully lower the large piston POS. 3 - A00388 manually.

THE JACK DOES NOT LIFT THE LOAD.

The pump unit will have to be replaced

THE JACK LIFTS, BUT COMES DOWN UNDER THE LOAD.

The block unit will have to be replaced

TECHNICAL DATA SHEET

Working air pressure	8 > 10 bar 116 > 145 psi	Weight	39 Kg 86 lb
Working temperature	-20°C > +50°C -4°F > 122°F	Max. stroke	150 mm 5.9 in
Air consumption	400 nl/min	1st stage capacity	44 t 40 ton (short)
Compatible oils	ATF Dexron IID	2nd stage capacity	22 t 11 ton (short)
Pneumatic system pipes	Rilsan ø 6x4 mm	3rd stage capacity	
		4th stage capacity	
		5th stage capacity	

Aerial Noise

Acoustic radiation pressure measured: 60 dBA

Tests carried out in conformity with the standards ISO/R 1680 - 1970. Instrument: LARSON DAVIS 800 B PRECISION ANALYSER PHONOMETER in conformity with the standards IEC 804 E 651 class 1 set with a Larson Davis Ca 250 114/b 250 Hz calibrator before and at the end of the measurements.

Measurements and dimensions - YAK 215/L

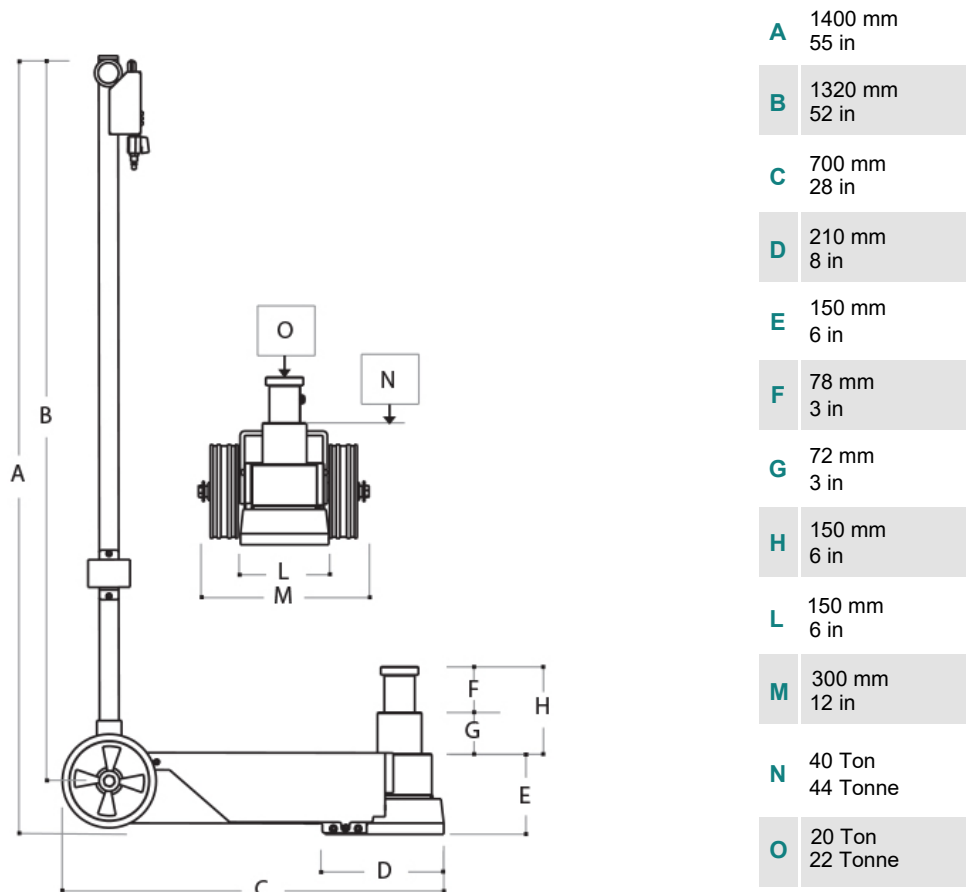

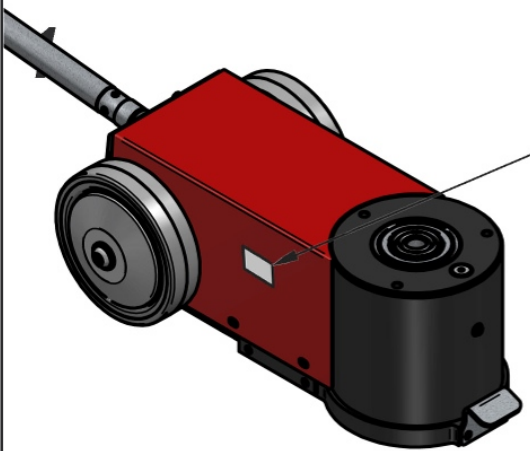

COMPANY NAME

CE Type:
Capacity: Ton.
Working air pressure: bar
Year of manufacture:
Serial number:
Made in ITALY

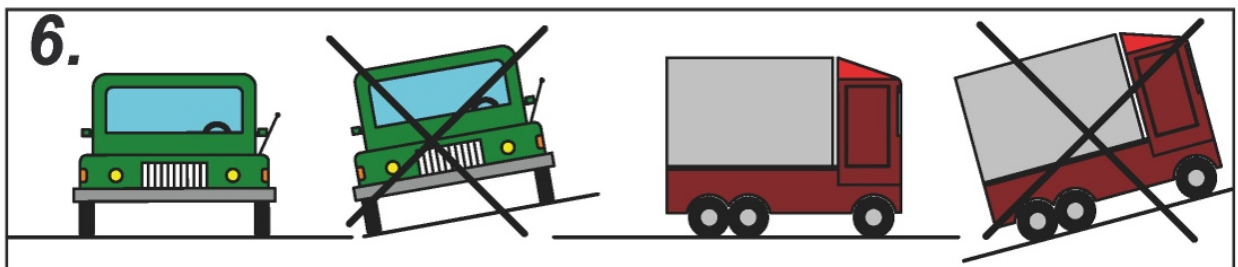
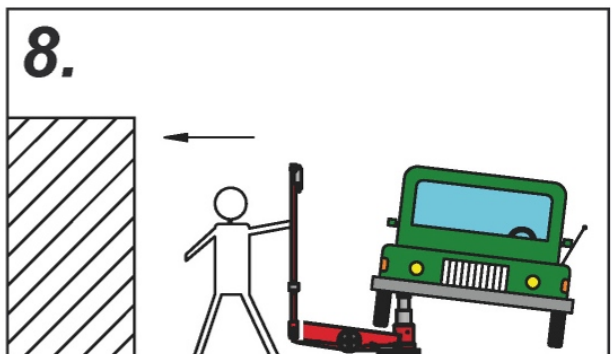
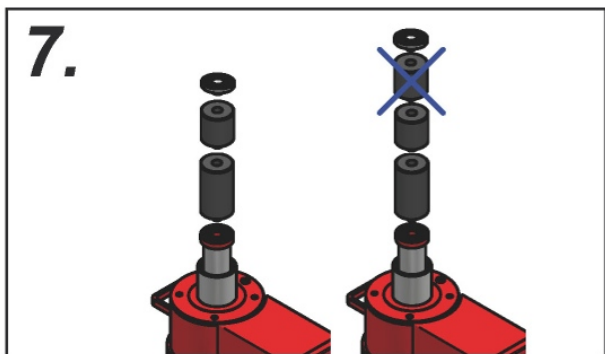
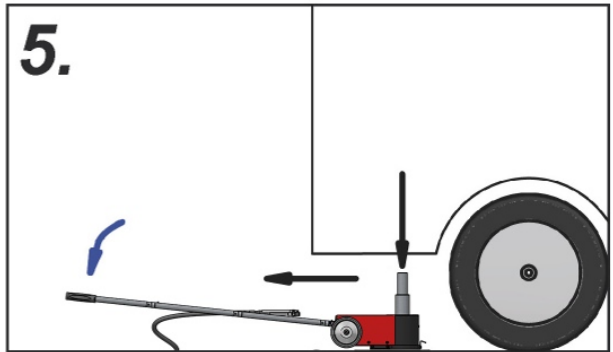
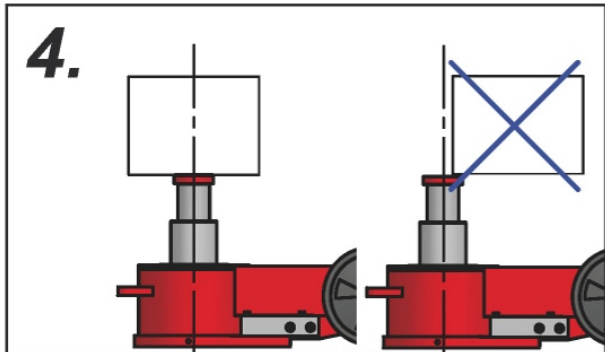
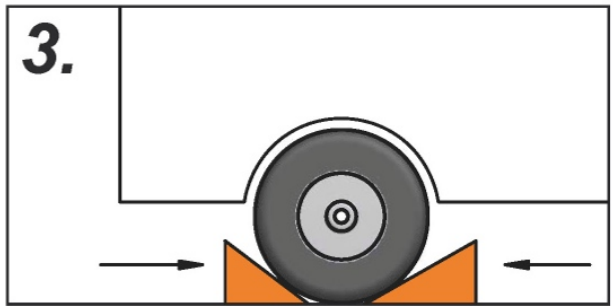
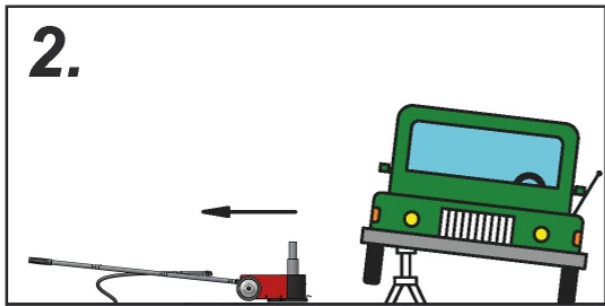

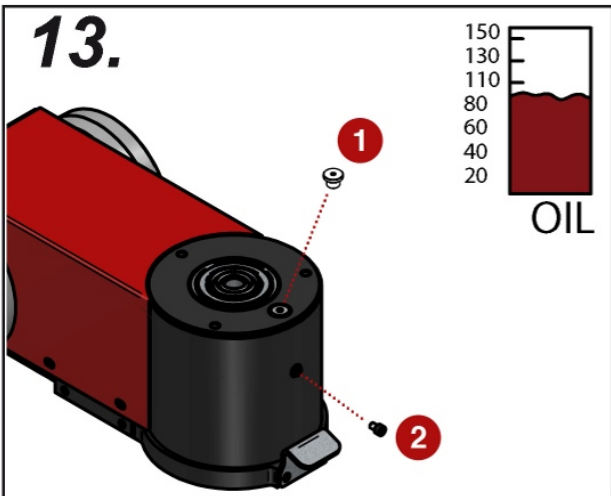
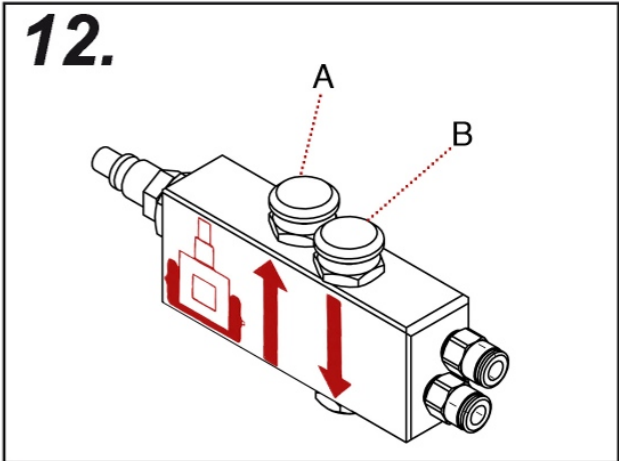
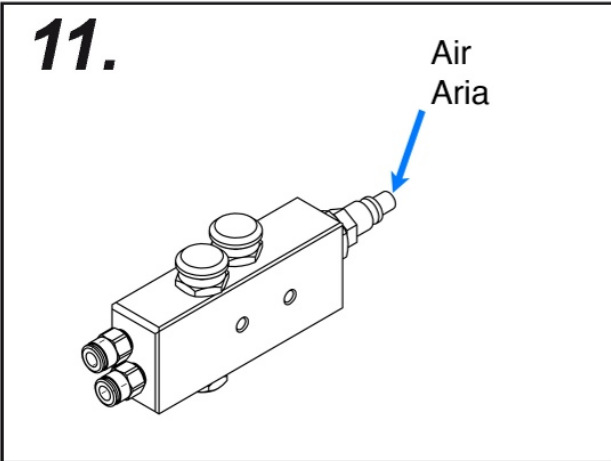
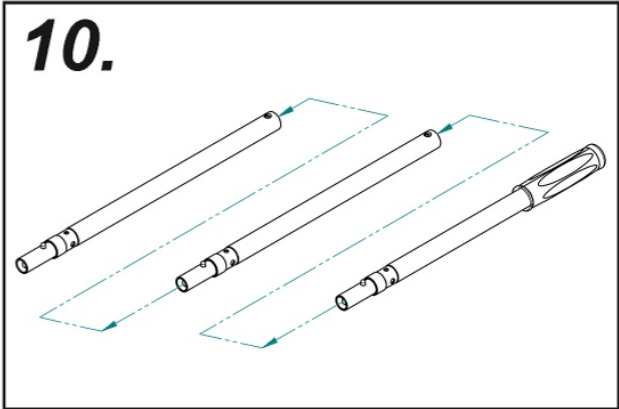
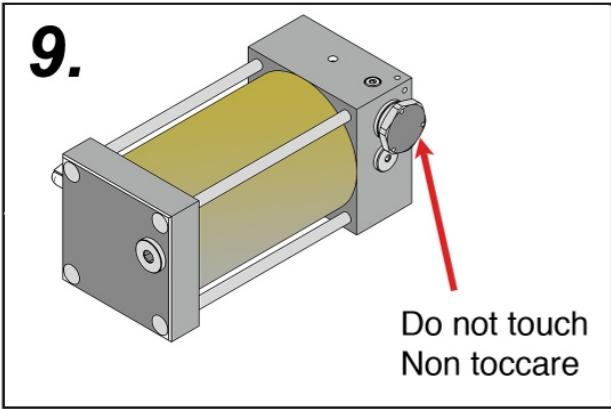

MODEL #92002 TROUBLESHOOTING

Connect jack to air

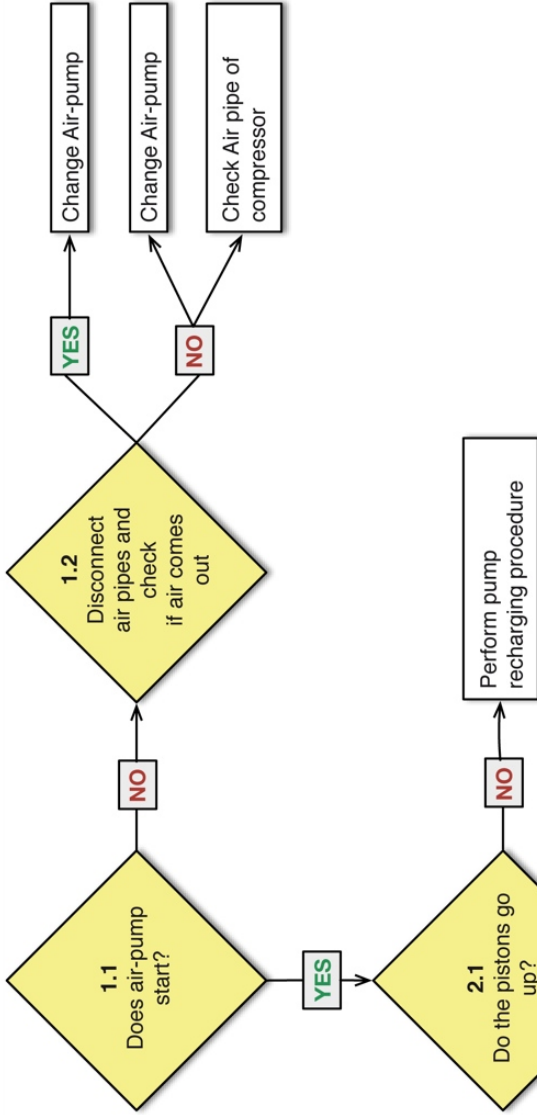

Put Jack under Load / Press

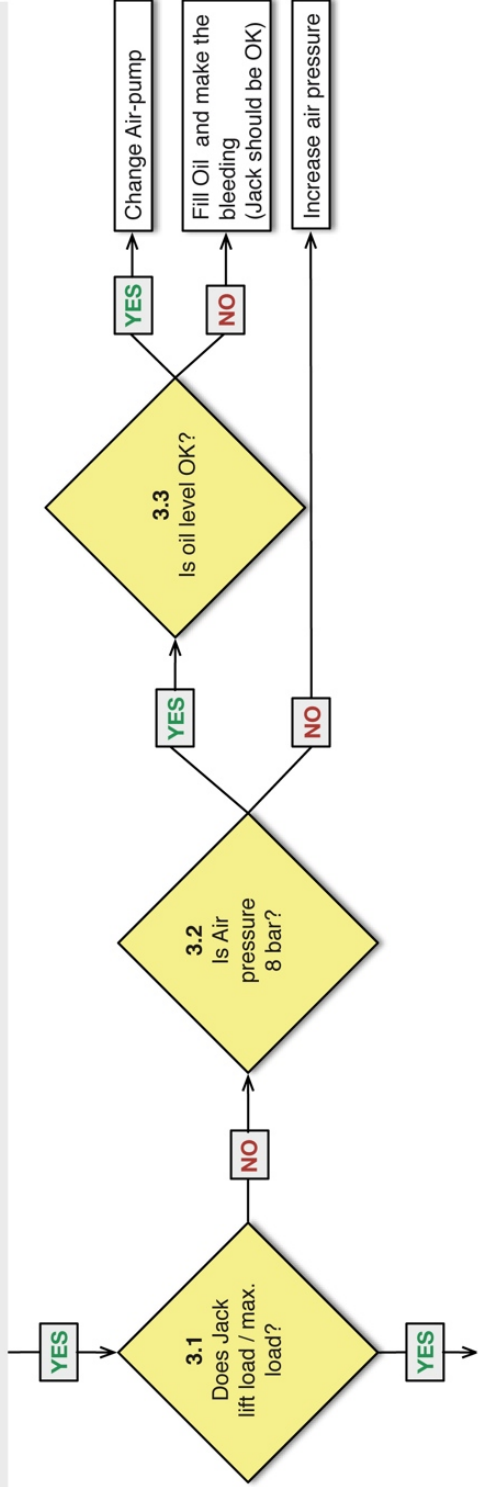

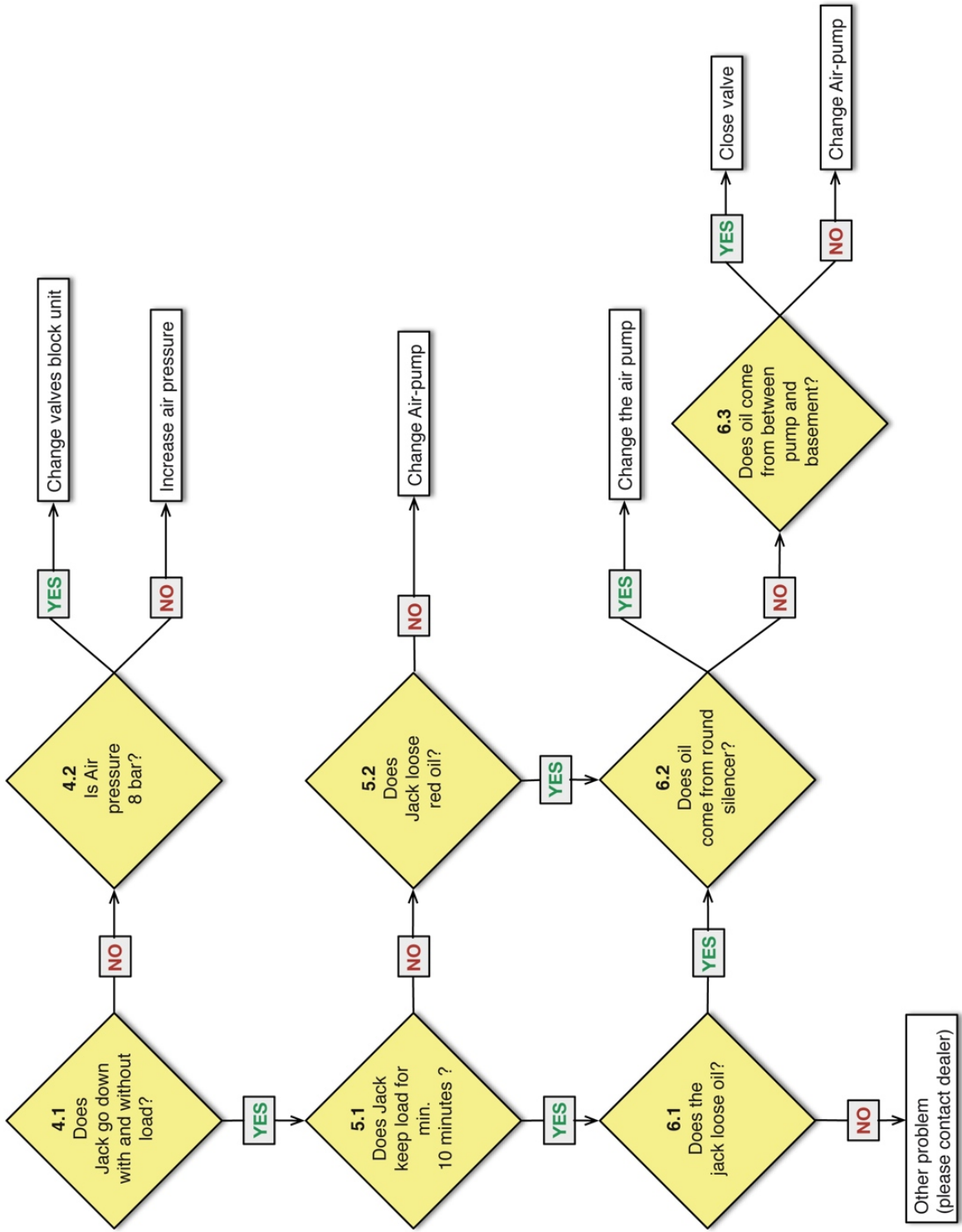

REQUESTING SPARE PARTS

WHEN ORDERING SPARE PARTS, THE FOLLOWING MUST BE SPECIFIED:

- 1) LIFT MODEL
- 2) SERIAL NUMBER
- 3) PART CODE (CODE)
- 4) DESIRED QUANTITY

SEALS KIT

KXYAK214/P

(KCYAK214/P + KMYAK214/P + KBYAK214/P)

Complete Seals kit

KCYAK214/P

Cylinder seals kit

KMYAK214/P

Motor pump seals kit

KBYAK214/P

Block seals kit

The Proper Tools To Keep Your Equipment **MOVING**



Scan this Code to Go to
the ESCO website

WWW.ESCO.NET



CONTACT INFO:

www.esco.net - info@esco.net

15270 Flight Path Drive

Brooksville, FL 34604

PH. 352.754.1117

Toll Free. 1.800.352.9852 (US, Canada Only)

Fax: 352.754.4508

ESCO - The Proper Tools to Keep Your Equipment Moving!

Stay Connected with ESCO...

