



AUTOMATIC DIGITAL WALL MOUNTED INFLATOR



Operating Instructions

MODEL 10964

1. Thank you for selecting this ESCO Automatic Digital Wall Mounted Inflator. Please read this manual before carrying out any installation or service procedure.
2. This manual is an integral and essential part of the product, please keep it away from damp, heat, dust, oils, do not remove, tear or amend any parts of the manual for any reason. It must be made available to the operator and to maintenance personnel, also to ensure staff training.
3. If you lose or damage the manual, ask the manufacturer for a copy, quoting the Part No. The manual must always remain with the machine, in the event of the machine being sold, it must be given to the new user.
4. The manufacturer reserves the right to change product features at any time without notice.

FEATURES

- Units of measure bar, psi, kPa, kg / cm²
- Inflates to 145 psi, 0.5 - 10 bar, 1000 kPa,~, 10 kg / cm²
- Large easy to read LCD display with audible warning
- Tough metal die cast body
- Individually calibrated and tested (see calibration certificate)

TABLE OF CONTENTS

Features	2
Components List	2
Installation.....	3
Warning.....	3
General Notes.....	3
Product Identification	4
Operation	5
Troubleshooting.....	6
Calibration Certificate.....	7
Specifications	8
Maintenance	8
Wiring Diagram	8

COMPONENTS LIST

Please check and make sure that the following components are complete in the package.

1. Automatic Tire Inflator with power cord
2. 33 ft. | 10m Air Hose
3. Hook and M6 x 38 screw kit (1pc)
4. User manual
5. M6 x 38 screw 4pcs for wall mounting

INSTALLATION

1. Unpack the unit.
2. Hold the unit up on the wall and mark where the four (4) holes are to be drilled.
3. Secure the unit using suitable fastener.
4. Connect the air supply to the unit.
5. Connect the rubber hose as air outlet.
6. Connect the power supply.

Warning:

1. This unit is connected directly to compressed air and this air contains oil and water. Water is from condensation and oil is from the compressor. **Water and oil will destroy this device**, so it is important to filter them out first from the system, this means you must attach a filter prior to this devices air connection.
2. Electrical connection should be carried out by qualified person strictly according to the related regulation applicable at the place where the inflator is used.
3. To avoid equipment damage, never exceed the maximum inlet pressure or
150 psi / 10.5 bar / 1050 kPa
/ 10.5 kg / cm²

WARNING

To avoid the risk of personal injury, especially to the eyes, face or skin, **DO NOT** direct the air stream at any person, or any part of the body.

This equipment is not intended for use by children without adult supervision.

When using the OPS function, the sum pressure must not exceed the tire manufacturer's maximum inflation pressure.

GENERAL NOTES

- During extended inactivity, please package the inflator and keep it away from damp, heat or impact, etc.
- After unpacking the inflator, the packing materials should be disposed of according to the laws and regulations applicable to the country being used.
- Please check carefully to ensure that no part is damaged, so to ensure safe and normal operation.
- The Automatic Tire Inflator can be installed outside, but a shelter is suggested, so to protect the equipment from the weather and extend the service life.



Fig. 1 Control panel



Fig. 2 Connections

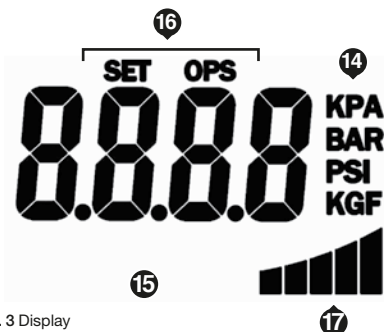

Fig. 3 Display

PRODUCT IDENTIFICATION

CONTROL PANEL

1. Mounting Point (x 4)
2. - Target pressure control
3. + Target pressure control
4. Display
5. FLAT TIRE / CONFIRM
Flat tire mode air Start/Stop control;
Function Select Confirm
6. Unit Option
Unit of measure select;
Over Pressure Setting set control
7. Programmable preset button 1
8. Programmable preset button 2

CONNECTIONS

9. Power cable
10. Pressurised Air Inlet
11. Air hose outlet
12. Exhaust plug
13. Buzzer (Audible warning)

DISPLAY

14. Unit of measure
15. Pressure display
16. Function selection
17. Rolling Bar

OPERATION

The device includes the OPS (Over Pressure Setting) function which allows for the tire's pressure to be set very high and then reduced to the pre-determined pressure. This is very handy for use when a new tire is fitted to a rim.

Unit of measure select:

This device has four units of measure that can be chosen by the user:

- kPa - kilo-pascals
- bar
- psi - pounds per square inch
- kg / cm² - kilograms per square centimeter

Once the unit is set here, it will become the default unit for following usage.

1. Press UNIT OPTION and SET will be shown on the LCD screen and the unit will be flashing.
2. Press + or - to choose the unit.
3. Press CONFIRM to confirm unit of measure.

Set OPS:

1. Press UNIT OPTION twice, SET and OPS will be shown on the LCD screen, OPS will be flashing
2. Press + or - to choose the OPS value.
3. Press CONFIRM to confirm. If OPS value is not zero, OPS will be displayed at the LCD screen.

Inflation and Deflation:

1. Press + or - to select target pressure.
2. Connect with tire, ensure no air leaks, inflator will start automatically.
3. When inflation is finished, the tire inflator will stop automatically and BEEP to warn users that inflation has reached target pressure.
4. Disconnect the air hose from tire.

Programmable Buttons:

1. Press P1 or P2 buttons once.
Press + or - to select pressure desired.
2. Press the CONFIRM button once and there will be a beep to confirm the programmable button has been set to the desired pressure.
3. You can set each programmable button to a different pressure.
4. If the unit is turned OFF the programmable buttons will have to be re-programmed.

Functions:

1. Press UNIT OPTION to enter the function setting mode. After selecting the unit, press UNIT OPTION again to enter the OPS setting directly, press UNIT OPTION three times and the device will exit out of the setting mode without saving the selection.
2. When OPS function is on, the device will inflate to target pressure plus OPS value first, then deflate to tire pressure desired, for example:
A final target of 32 psi or 2.2 bar with an OPS setting of 16 psi or 1.1 bar gives a sum of 48 psi or 3.3 bar. This sum of 48 psi or 3.3 bar is the Over Pressure setting for the tire. The tire will inflate to the sum value and deflate to the final target pressure.
3. If tire pressure is lower than 3 psi or 0.2 bar, the device will not start automatically. Press FLAT TIRE for 2 seconds to start manually.
4. During inflation, the device will check tire pressure automatically, the rolling bar shows inflation/deflation in progress and left to right means inflating, right to left means deflating.

TROUBLESHOOTING

PROBLEM	POSSIBLE CAUSE	SOLUTION
Air leak	Leak in the connection	Check the pneumatic connection and
The inflator works, but no air inflated	Obstruction in the filters or in air system	Clean the filters and check the air tube
Inflation does not start, although the pressure is set and the hose is connected to the tire	Air hose improperly connected	Check the hose connection, make sure that no air leaks
	Tire pressure is below 0.2 bar (3 psi)	Press FLAT TIRE 
The unit deflates very slowly	The exhaust plug is blocked	Remove and clean the exhaust plug
Er1	Pressure sensor broken	Power off, change pressure sensor
Er2	Unstable pressure, faulty hose connector	Replace hose connector or re-connect hose to the tire
Er3	Connected tire pressure is too high > 188.5 psi 13 bar	Stop inflating the tire
Er4	Wrong connections at air inlet and outlet	Refer to wiring diagram and connect magnetic valve accordingly
Er5	Low voltage	Check the power supply
Er6	Calibration error	Unit requires calibration
Er7	Calibration error	Unit requires calibration
Er8	Air supply lower than set inflate pressure	Increase air supply pressure or Stop inflating this tire

CALIBRATION CERTIFICATE

This Digital Wall Mounted Inflator has been calibrated in its normal working position on test equipment with an accuracy that is traceable to International Standards according to: 86/217/EEC

ALLOWABLE TOLERANCE		
BAR	±0.08	up to and including 4 bar
	±0.16	between 4 bar and 10 bar inclusive
	±0.25	greater than 10 bar
p.s.i.	±1.2	up to and including 58 psi
	±2.3	between 58 and 145 psi inclusive
	±3.6	greater than 145 psi

TEST RESULT				
REFERENCE PRESSURE				
<input type="checkbox"/> BAR <input type="checkbox"/> PSI				
DISPLAY PRESSURE				
<input type="checkbox"/> BAR <input type="checkbox"/> PSI				

Serial Number: _____

Date: _____

SPECIFICATIONS

Case	Heavy Duty Metal Housing
Hose Length	32 ft. 10m
Dimensions	190L x 150W x 70H mm
Weight	13 lbs. 5.5 kg
Scale	174 psi / 12 bar (1200 kpa / 12 kgf)
Accuracy	±0.3 psi @ 25-75 psi
Max. inlet air supply	174 psi 12 bar
Supply voltage	110-240V AC (50-60 Hz)
Wattage	12 W Max.
Working temperature	15-120° F -10 - 50° C
Relative humidity	up to 95% RH non-condensing

MAINTENANCE

Daily Maintenance

The device does not require a particular maintenance routine but a check of the pneumatic connection is suggested frequently to make sure of correct air supply, the use of an air pre-filter is essential for this unit to operate properly.

Special Maintenance

This is a sensitive piece of equipment if you have an error that cannot easily be fixed please contact an authorized service agent.

WIRING DIAGRAM

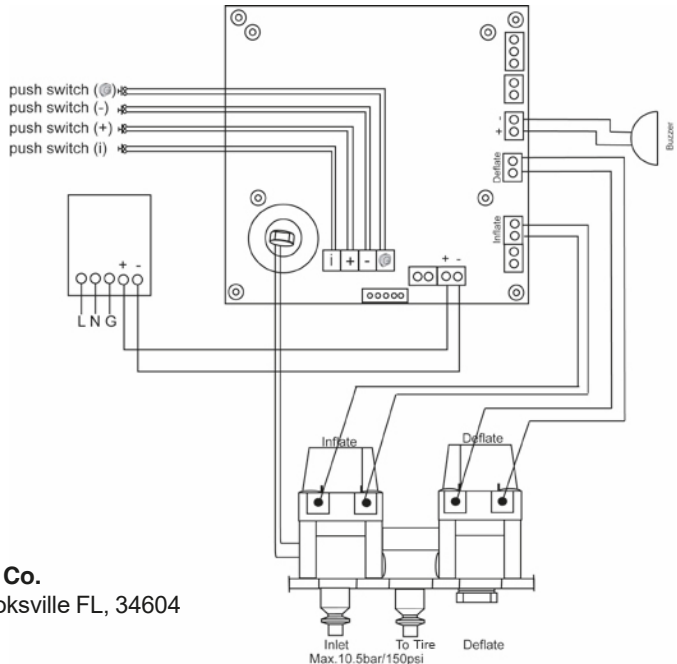

Distributed by
ESCO - Equipment Supply Co.
 15270 Flight Path Drive, Brooksville FL, 34604
 info@esco.net

For more information contact Customer Service on
 1-800-352-9852

www.esco.net