

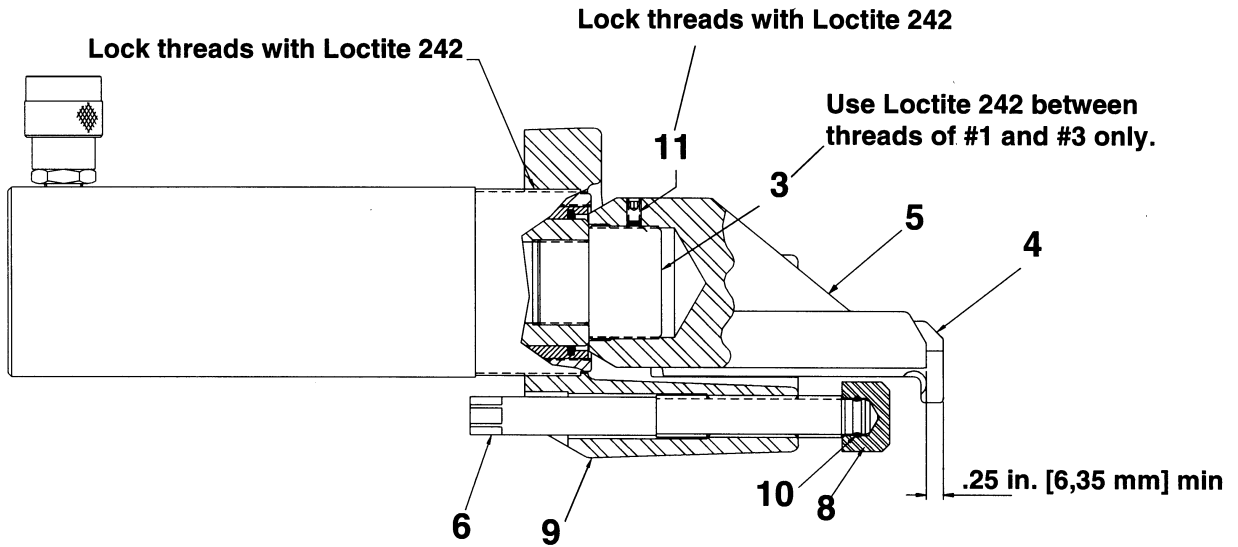

Repair Parts Sheet

10103 (OTR-2000E) BEAD BREAKER

*NOTE – Identifying feature DA Number on plunger Item #5



CAUTION
 The OTR-2000E Bead Breaker, and all tire tools, should be used only by persons properly trained according to OSHA regulation #29CFR1910.177, "Servicing Single-Piece & Multi-Piece Wheels"

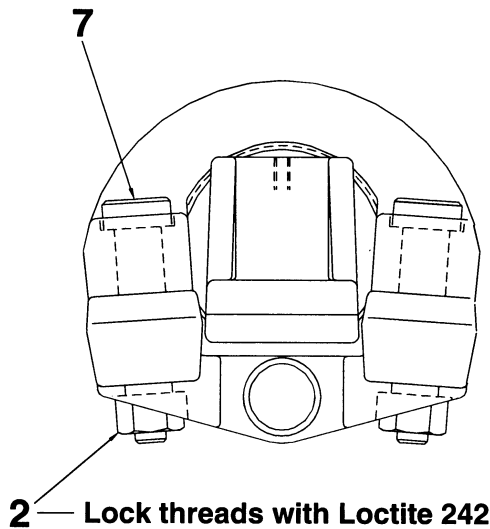

Repair Parts List

ITEM	PART NO.	QTY.	DESCRIPTION	ITEM	PART NO.	QTY.	DESCRIPTION
2	B1013122	2	Hex Nut	7	DA11799130	2	Shoulder Bolt
3	DA12376038	1	Adapter Thread	8	28705	1	Pressure Nut
4	DA11663157	2	Hook	9	DA11667038	1	Frame
5	DA11665040	1	Plunger	10	DA11816049	1	Retainer Ring
6	34184	1	Screw Set	11	DA751027	1	Set Screw



Cylinder Assembly

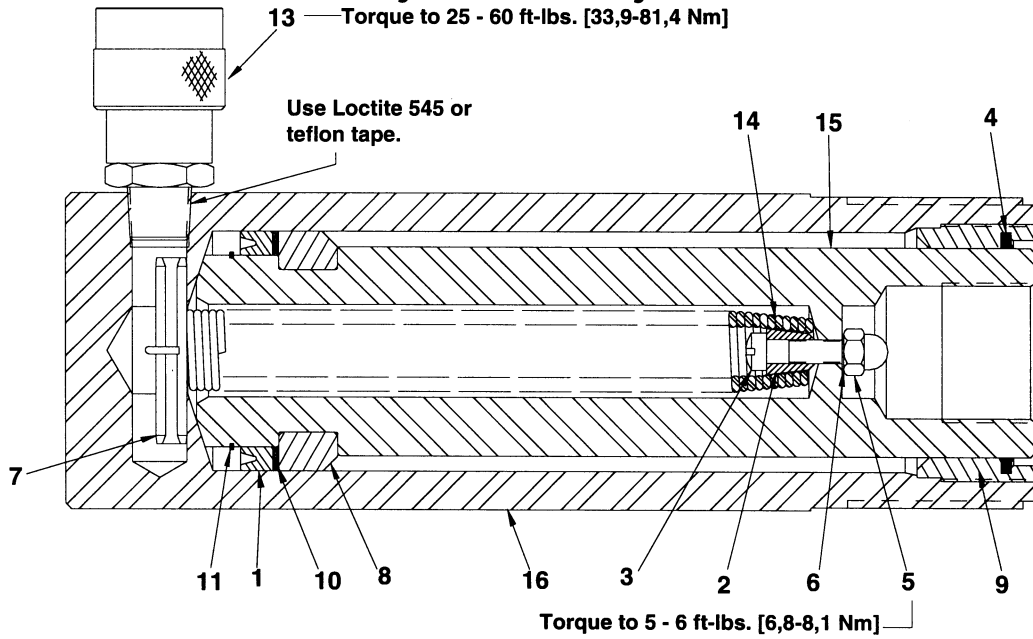

Repair Parts List

ITEM	PART NO.	QTY.	DESCRIPTION	ITEM	PART NO.	QTY.	DESCRIPTION
1	*CH800041	1	U-Cup	9	G89044	1	Stop Ring
2	F948209	1	Bushing	10	*G907108	1	Washer
3	B1014028	1	Screw	11	*G908044	1	Retaining Ring
4	*G731044	1	Wiper Ring	13	10606	1	Female Coupler
5	G833055	1	Nut	14	F937110	1	Spring
6	*G834167	1	Gasket	15	G897040	1	Plunger
7	B1157057	1	Pin	16	BSG894005	1	Cylinder
8	G898107	1	Bearing				

* Indicates parts available in Repair Kit RC2510K





EQUIPMENT SUPPLY COMPANY

Instruction Sheet

OTR-2000E (10103) Tire Bead Breaker

L2191

Rev. O

10/97

IMPORTANT RECEIVING INFORMATION

Visually inspect all parts for shipping damage. If you find shipping damage, notify the carrier at once. Shipping damage is not covered by your warranty. The carrier is responsible for all costs of replacement or repair caused by shipping damage.

CONTENTS

ENGLISH.....	1-6	FRANÇAIS	13-18	ITALIANO	25-30
DEUTSCH	7-12	ESPAÑOL	19-24	NEDERLANDS	31-36

DESCRIPTION

The OTR-2000E Bead Breaker is used on 39", 45", 49", 51", 57", and larger multi-piece rims with pry bar pockets. The OTR2000E has a 6.25" stroke and is designed to break giant off-the-road tire beads on any rim. It can be used with a model AHP15T, AHP25TP, AHP35T, or equivalent 10,000 psi [700 bar] pump. When working with 39", 45", 49", 51", 57" rims, use the OTR-1825D (10100) or OTR-1600 (10102) until you get enough room to install the OTR-2000E.

SAFETY INFORMATION

To avoid personal injury or property damage while using this product, read and follow all **DANGERS, WARNINGS, CAUTIONS, and INSTRUCTIONS** that are attached to, or included with, this product.

1. Follow the instructions of the tire manufacturer and the vehicle manufacturer when deflating, demounting, mounting, and inflating tires.
2. These operating instructions do not apply to any specific rim. Therefore, contact the rim manufacturer for the correct procedure for your rim.
3. For the publication, "Multipiece Rim Matching Chart" contact the United States Department of Labor, Occupational Safety, and Health Administration (OSHA), Washington, DC, 20210, 202-219-6091, or contact ESCO at 1-800-352-9852. If you are outside the U.S., contact your local government officials.
4. ESCO cannot be held responsible for damage or injury resulting from unsafe use of this product, lack of maintenance, or incorrect product and system application.
5. Contact ESCO when in doubt about safety precautions or applications.

▲ CAUTION

The bead breaker, and all tire tools, should be used only by persons properly trained according to OSHA Regulation #29CFR1910.177, "Servicing Single-Piece & Multi-Piece Wheels." Free copies of this regulation are available upon request from ESCO.

▲ WARNING

To avoid serious personal injury, always wear proper protective gear, such as hard hats, safety glasses, gloves, and steel toe shoes when using hydraulic equipment.

OPERATING INSTRUCTIONS

REMOVING THE WHEEL

1. Chock the wheels opposite the jack.
2. Jack up the vehicle.
3. Crib the vehicle with safety stands or blocking devices after jacking it up. Do not work under an unblocked load.

▲ DANGER

Failure to chock the wheels and crib the vehicle can result in serious injury or death.

4. Remove the valve core; deflate tires completely. (See Fig. 1.)
5. Insert a thin piece of wire through the valve stem to make sure air is flowing freely and the valve stem is not blocked.

NOTE: Deflate both tires if you have a dual mounting.

▲ DANGER

Always deflate tires before removing a wheel, a rim, or part of a rim, such as a rim clamp or nut. If you do not deflate the tire, the tire could explode, causing serious injury or death.

6. Remove the tire/rim assembly from the vehicle and place it flat on the ground with the gutter side up. (See Fig. 2.)

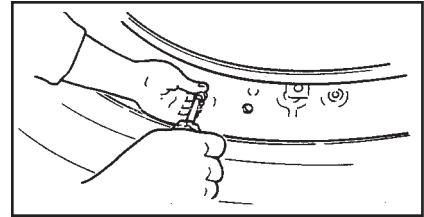

Figure 1

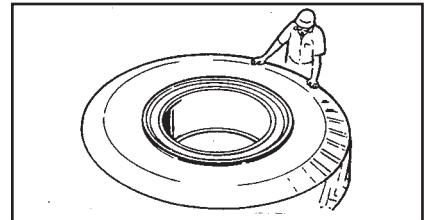

Figure 2

USING THE OTR-2000E BEAD BREAKER

Positioning the Bead Breaker

1. Place the bead breaker into the continuous pry bar pocket, with the hooks under the lip of the bead seat band. (See Fig. 3.)
2. Position the bead breaker so that it is about 30°, or at least 12 inches [0,3 m], to one side of the flange butt weld.
3. Adjust the ram adjusting screw so that the bead breaker is perpendicular (90°) to the wheel. (See Fig. 3.) In some cases you may have to use an OTR-1825D (10100) or OTR-1600 (10105) to move the rim flange far enough back to insert the larger OTR-2000E (10103) tool.
4. Stand to one side of the bead breaker. Hold the bead breaker with one hand. (See Fig. 4)

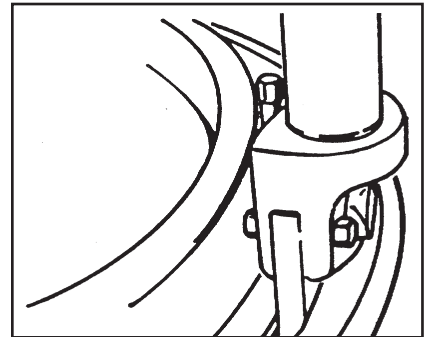

Figure 3

▲ DANGER

Always stand to one side of the rim when using the bead breaker. Standing to one side of the bead breaker allows you to maintain control of the bead breaker. If it is not seated properly and flies off the rim, the bead breaker could cause serious injury or death.

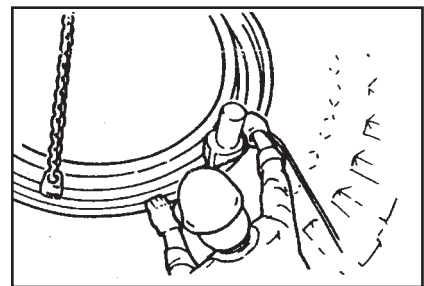

Figure 4

Activating the Bead Breaker

⚠ CAUTION

The bead breaker uses a long stroke and high force. Be careful not to damage or bend rim parts, such as the flange butt weld, when using the bead breaker.

1. Turn on the hydraulic pump to activate the bead breaker.
2. Apply enough hydraulic pressure to the bead breaker to push the flange about 1/2-3/4 inch [13-19 mm] from the lip of the bead seat band.
3. If the bead breaker moves and is no longer vertical, readjust the ram adjusting screw. You must release pressure before adjusting the screw.
4. Continue applying hydraulic pressure until the flange is about 3/4-1 inch [19-25 mm] from the lip of the bead seat band.
5. Place a nut or similar object between the flange and the lip of the bead seat band. (See Fig. 5.)

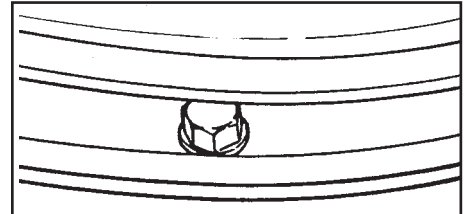

Figure 5

⚠ WARNING

To prevent personal injury, lay the nut on the flange and slide it into position with two screwdrivers. Do not put your fingers under the bead seat band.

6. Release hydraulic pressure.

Continuing to Break the Tire Bead

1. Move the bead breaker away from the flange butt weld, 2-3 feet [0,5-1,0 m] from its present position.
2. Follow the steps in “Activating the Bead Breaker” above.
3. Continue advancing the bead breaker around the rim, 2-3 feet [0,5-1,0 m] at a time, breaking the tire bead.
4. Stop breaking the tire bead when you have moved the bead breaker about 3/4 of the way around the rim. (See Fig. 6.)

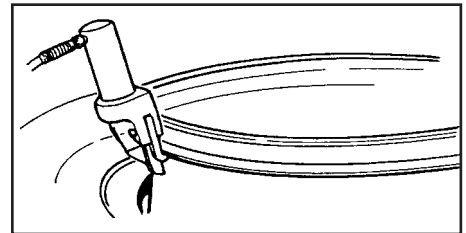

Figure 6

⚠ CAUTION

To prevent damage to the rim, do not use the bead breaker within 12 inches of the flange butt weld.

5. Apply enough pressure to the bead breaker to completely break the tire bead.
6. Release the hydraulic pressure.

NOTE: If you have gone all the way around the tire and the tire bead does not break: Repeat the steps in “Activating the Bead Breaker” and “Continuing to Break the Tire Bead” above, with more hydraulic pressure.

Removing the Lock Ring and O-Ring

1. Stand inside the tire rim. Remove the lock ring with two pry bars. Start at the split in the ring and then work the tools around the ring. (See Fig. 7.)
2. Place a pry bar or screwdriver under the o-ring and pull it out from the groove in the rim. Cut the o-ring with a knife to ensure that a new o-ring is used. (See Fig. 8.)

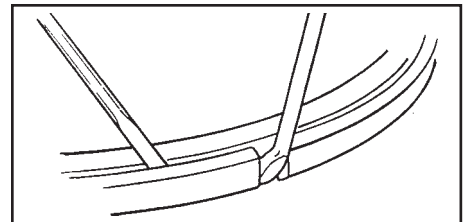

Figure 7

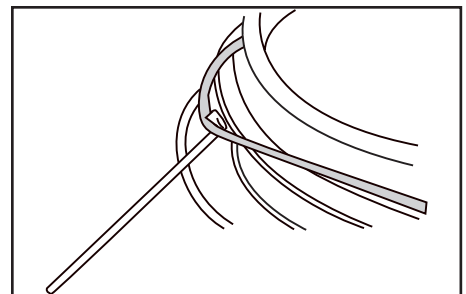

Figure 8

Removing the Bead Seat Band

1. Carefully lift the bead seat band off the rim. Use a hoist, pry bars, and the ESCO Flange Ring Puller Model 90300. (See Fig. 9.)
2. Carefully remove the flange from this side of the tire.
3. Using a hoist and ESCO Tire Sling Model 90100, turn the tire/rim assembly over on the other side.

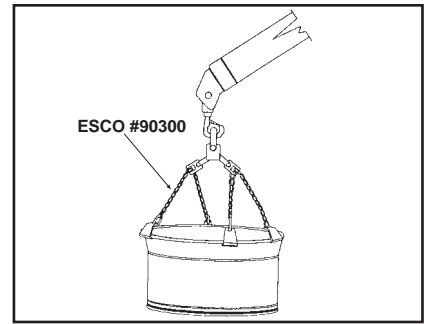

Figure 9

Breaking the Bead on the Other Side

1. Break the tire bead on this side of the tire by repeating the steps in **USING THE OTR-2000E BEAD BREAKER** on pages 2 and 3.
2. Using a hoist, lift the rim base from the tire. Using the ESCO Flange Ring Puller Model 90300 will make handling easier. (See Fig. 10.)
3. Remove the flange from this side of tire.

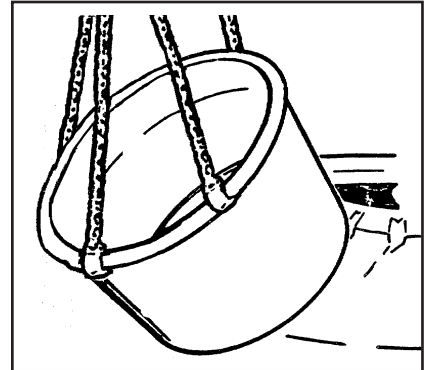

Figure 10

MOUNTING AND INFLATION

Jacking Up the Vehicle

1. Chock the wheels opposite the jack.
2. Jack up the vehicle.
3. Crib the vehicle with safety stands or blocking devices after jacking it up. Do not work under an unblocked load.

▲ DANGER

Failure to chock the wheels and crib the vehicle can result in serious injury or death.

Inspecting the Tire and Rim

▲ DANGER

Always replace damaged or badly worn tires. When replacing tires, always use a replacement of exactly the same diameter. Destroy old tires, so that they cannot be used. Using badly worn or damaged tires can result in serious injury or death.

1. Inspect all rim parts for damage.

▲ DANGER

Always replace rim parts that are bent, badly rusted, pitted from corrosion, cracked, worn, or damaged. Destroy old rim parts, so they cannot be used. Using damaged rim parts can result in serious injury or death.

Do not mix parts from one rim with parts from another rim. Always use replacement parts that you can positively identify as the **CORRECT** replacement parts. All replacement rim parts **MUST** match the replacement part numbers stamped on the rim parts. Rims with different part numbers cannot be interchanged. If in doubt about sizing, **DO NOT** reassemble the rim. Contact the rim manufacturer for more information.

2. Replace damaged parts.

▲ DANGER

Never weld on an inflated or partially inflated tire/rim assembly. Welding on an inflated tire/rim assembly can cause an explosion and serious injury or death.

Do not rework, weld, heat, or braze any rim parts for any reason. Reworking and welding damaged parts can result in serious injury or death.

3. Clean and repaint rim parts as necessary.

NOTE: Remove rust, dirt, and foreign material from rim parts. Repainting the rim parts and bare metal areas will make them last longer. Be careful to keep paint out of the lock ring groove in the gutter when repainting rim parts.

4. Visually inspect all tire and rim parts to make sure they are positioned properly.

Starting to Inflate the Tire

1. To comply with OSHA Regulation #29CFR1910.177, place the tire in a safety cage or other restraining device, such as an ESCO Push Bar Model 90201, before inflating the tire. Use a clip-on air chuck and hose that is long enough to allow you to stand outside the wheel trajectory. The air line must be equipped with an in-line valve with pressure gauge or regulator that can be preset. Use ESCO Truck Tire Inflator Model 15136.

⚠ DANGER

Always use a safety cage or restraining device, such as an ESCO Push Bar Model 90201, when inflating a tire. Not using a safety cage or restraining device can result in serious injury or death.

Always use a clip-on air chuck and a hose that is long enough to allow you to stand outside the wheel trajectory. The air line must be equipped with an in-line valve with a pressure gauge and a regulator that can be preset.

Never use starting fluid, ether, gasoline, or any other flammable material to lubricate, seal, or seat the bead of a tubeless tire. Doing so can cause an explosion and serious injury or death.

2. Inflate the tire to 5 psi [0,345 bar].
3. Check all tire and rim parts again for proper positioning. Make sure the o-ring does not slip out of its groove.
4. If tire/rim parts are not seated properly, deflate the tire and correct the problem before proceeding.

⚠ WARNING

Never hammer, strike, or pry an inflated or partly inflated tire/rim assembly. If you must seat a part or correct a problem, always deflate the tire first.

⚠ CAUTION

Do not use a steel hammer on rim or rim parts. This can damage the rim. If you must reposition tire or rim parts, use a rubber, plastic, or brass-faced hammer.

If a tire/rim assembly does not slide over a cast spoke wheel, do not force the assembly by hammering. Instead, deflate the tire and inspect for warped or incorrectly seated parts, such as lock rings.

5. If tire and rim parts are seated properly, proceed to “**Finishing the Tire Inflation**” below.

Finishing the Tire Inflation

1. Inflate the tire to 20 psi [1,38 bar].
2. Check the tire bead for proper seating.
3. Continue inflating the tire to 40 psi [2,76 bar] If the tire bead is not fully seated, see the **Warning** below. If the tire bead is fully seated, continue with Step 4 below.

⚠ WARNING

Never inflate a tire beyond 40 psi [2,76 bar] to seat a tire bead. If the tire bead is not fully seated at 40 psi: Stop! Deflate the tire and correct the problem.

4. Once you see that the tire bead is fully seated at 40 psi [2,76 bar], deflate the tire completely.
5. Reinflate the tire slowly to the manufacturer's recommended pressure.

 DANGER

Inflate and load tires only to manufacturer's specifications. Over-inflating and overloading tires can result in serious injury or death.

Never run a vehicle with only one tire of a dual assembly. Doing so can result in a collapse of the vehicle and lead to serious injury or death.