



EURO BEAD BREAKER

MODEL #10107



Instruction Manual Parts Breakdown

Contact us at:
Phone: 352-754-1117
Toll Free: 1-800-352-9852 U.S ,Canada, and Caribbean Only
Website: www.esco.net
15270 Flight Path Drive • **Brooksville, FL • 34604**

Operation



WARNING

The optional air/hydraulic pump is capable of generating fluid pressure up to 10,000 PSI. Keep both hands on the handles and away from the clamping jaw or breaker tongue. Make certain that the tool is properly aligned on the rim before allowing the bead breaking action. Do not continue to operate the air/hydraulic pump once the breaker rod is completely extended. Failure to comply with these instructions could result in personal injury or equipment damage.

To operate the bead breaker:

- 1 Make certain the tire is completely deflated. Using rubber lubricant, lubricate the area where you plan to break the bead.



Deflate tire.



Lubricate with rubber lubricant.

- 2 Connect the hose of an air/hydraulic pump to the hydraulic coupling on the bead breaker tool. Connect the air supply line to the air/hydraulic pump. The air supply should be between 5 and 10 CFM at 100 PSI to obtain proper operating characteristics. In addition, the air line should be equipped with an air line filter.
- 3 Position the bead breaker so that the jaw makes solid contact with the rim and the teeth are positioned in the crevice between the bead of the tire and the rim.

NOTE

When a tire has a trash guard, you may have to drive two straight tire irons between the rim and the tire bead to get a starting point for the teeth.

- 4 Step on the PUMP end of the pump pedal. The clamping rod will begin to extend and the jaw will grip the rim.

The Model #10107 includes a clamping jaw pivot pin which can be placed in one of four jaw pivot positions for use on different wheel diameters. The top hole (closest to the handle) is used for smaller wheel diameters, and the bottom hole (furthest from the handle) is used for larger wheel diameters.

Contact us at:

Phone: 352-754-1117

Toll Free: 1-800-352-9852 U.S., Canada, and Caribbean Only

Website: www.esco.net

15270 Flight Path Drive • Brooksville, FL • 34604



CAUTION

Make certain that the teeth slip in between the rim flange and the bead. If not, depress the RELEASE end of the pump pedal and realign the tool. If the tool is not positioned correctly, extending the breaker rod may damage the tire bead or sidewall, the rim flange, or the tool. If the tool is not pushing parallel to the bead seat area, reposition before continuing.

- 5 Continue pumping until the tongue of the bead breaker pushes the bead free of the rim.
 - 6 Repeat the process as needed around the diameter of the rim. The tool can be used on the front and back bead areas.
 - 7 Once the bead is free of the rim, depress the RELEASE end of the pump pedal.
-

Service

Most bead breaker malfunctions are a direct result of foreign matter, such as dirt, dust, water, etc., entering the tool through the open hydraulic coupler union. Keep the union clean and capped when the pump is not connected to the tool to reduce contamination.

Tools which may be required for bead breaker service include:

- 1 Spanner wrench
- 2 Common screwdriver
- 3 Needle-nosed pliers
- 4 Ice pick or sharp awl
- 5 Allen wrenches (Metric)
- 6 Open end wrenches
- 7 Retaining ring pliers
- 8 Socket wrenches
- 9 Ratchet
- 10 Torque wrench



Purging Air

These instructions are designed for use with the ESCO Air/Hydraulic Pump. If using a different pump, use this information as a guide only. Purge air from the pump and bead breaker as follows:

- 1 Remove the snap rings on the rod connectors (items 35 and 38 on the parts drawing).
- 2 Connect the air/hydraulic pump to the tool.
- 3 Connect the pump to the air supply.
- 4 Position the pump so that it is higher than the tool and depress the PUMP end of the pedal.
- 5 After the clamping and breaker rods are fully extended, depress the RELEASE end of the pedal. Repeat this cycle (PUMP - RELEASE) about five times.
- 6 Extend both rods and keep them extended. Check for leaks. Make certain that the rods do not "creep" back into the cylinders.

Cleaning

Wash the exterior of the bead breaker with warm, soapy water. Rinse with clean water and blow the tool dry with an air nozzle. Also pay particular attention to the cleanliness of the pump.

CAUTION

Avoid seal damage. Do not use solvent to clean the bead breaker.

Storage

Prior to storing the bead breaker:

- 1 Completely retract both rods. An exposed rod may be subject to rusting, pitting and damage from striking other tools.
- 2 If chloride is spilled on the tool, rinse with clean water and blow dry.
- 3 Dress rod surface nicks and dents with fine grit emery paper. Rod surface nicks and dents, if left untended, provide a starting point for rust.

NOTE

The chrome plated rod surfaces provide the seal for the tool. Any steps taken to ensure the continuing quality of the rod surfaces will increase the service life of the tool.



Hydraulic Flow

Use the hydraulic flow information to help troubleshoot problems with the ESCO Euro Bead Breaker

The bead breaker works via an air/hydraulic pump which supplies hydraulic fluid pressure to the clamping cylinder. Fluid pressure is restricted to the clamping cylinder by spring pressure on the sequence ball and by the mated surfaced of the fluid return ball and its seat. As the clamping rod moves out of the cylinder, the jaw clamps firmly on the rim.

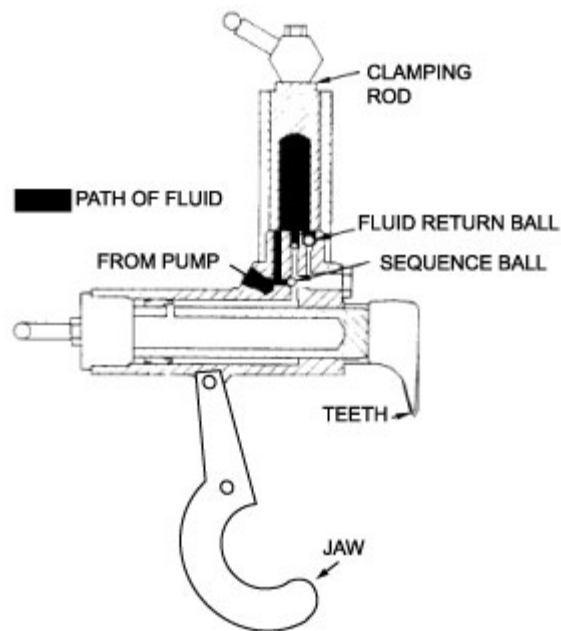

The internal hydraulic pressure of the clamping cylinder is sufficient to overcome the spring pressure against the sequence ball. The ball is forced away from the seat and pressure increases inside the breaker cylinder.

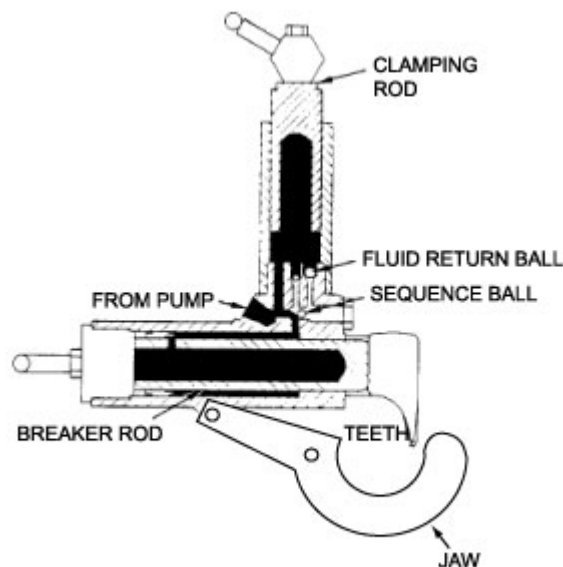



Hydraulic Flow

The breaker rod has moved out of the cylinder and the tongue is pressing against the bead. As pressure increases, the tongue will break the bead of the tire from the rim.

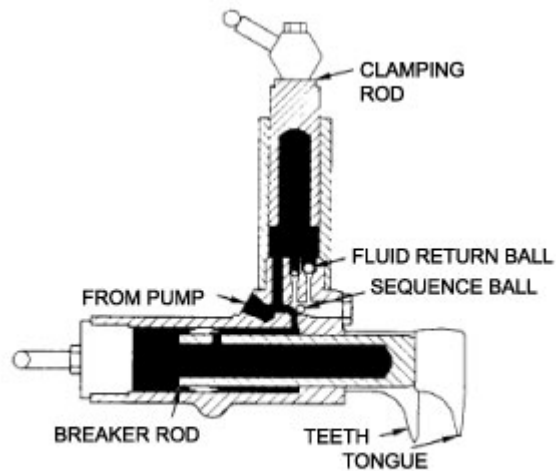

Depressing the RELEASE pedal causes a decrease in pressure in the clamping cylinder. With less pressure on the clamping cylinder side of the fluid return ball than on the breaker side, the fluid return ball is lifted off the seat and the breaker rod retracts. Retraction is due to an internal spring and pressure of the bead against the tongue. The breaker rod retracts first, followed by the clamping rod.

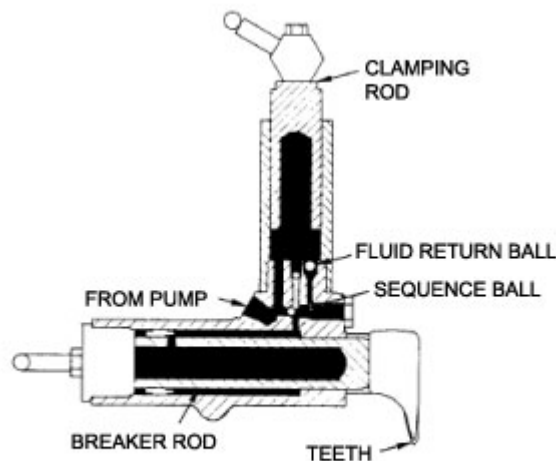

NOTE

The clamp can be adjusted for different rim widths. Open the clamp wider for larger rim widths.



Troubleshooting

SYMPTOM	PROBABLE CAUSE	RESOLUTION
Rods extend too slowly.	Insufficient hydraulic pressure from pump.	Check air supply.
		Check clearance of inlet check ball. Ball must be flush with or below end of filter adapter.
Rods fail to retract.	Hydraulic pump does not release.	Dirt under pedal in release valve area. Clean pedal.
	Bearing is misaligned on breaker rod.	Correct or replace.
	Broken or weak springs.	Replace.
Both rods extend at the same time. Hydraulic pressure in breaker cylinder is not being released.	Sequence ball not seated, or spring is broken or weak.	Correct or replace.
	Loose screw and ball not seated.	Correct or replace.
Breaker rod retracts after clamping rod. Hydraulic pressure in breaker cylinder is not being released.	Fluid return ball did not restart.	Correct or replace.
	Dirt plugging return port.	Clean port.
	Weak or broken spring in breaker cylinder.	Replace.
Pump does not reciprocate.	Air piston stuck.	Check cylinder bore of pump for contamination or lack of lubrication.
	Piston poppet not sealing.	Replace.
Pump reciprocates. Ram will not extend.	Check prime.	Depress both air valve and hydraulic release valve at the same time.
Pump extends ram but will not hold system pressure.	Outlet check ball not sealing properly.	Correct or replace.
	Release valve mechanism not sealing properly.	Check pin, ball, release poppet, and poppet retainer. Correct or replace.
Pump extends ram but will not build to maximum pressure. No visible sign of leakage.	Check air supply.	5 - 10 CFM at 100 PSI
	Check for internal leakage.	Release valve mechanism.
		Low relief valve setting.
		Inlet check ball not seating properly. Correct or replace.
Pump extends ram but will not build maximum pressure. Visible sign of leakage through exhaust muffler.	Check piston sub-assembly.	Replace copper gasket and assemble in vertical position.
		Replace piston packing.



EURO BEAD BREAKER

Model #10107

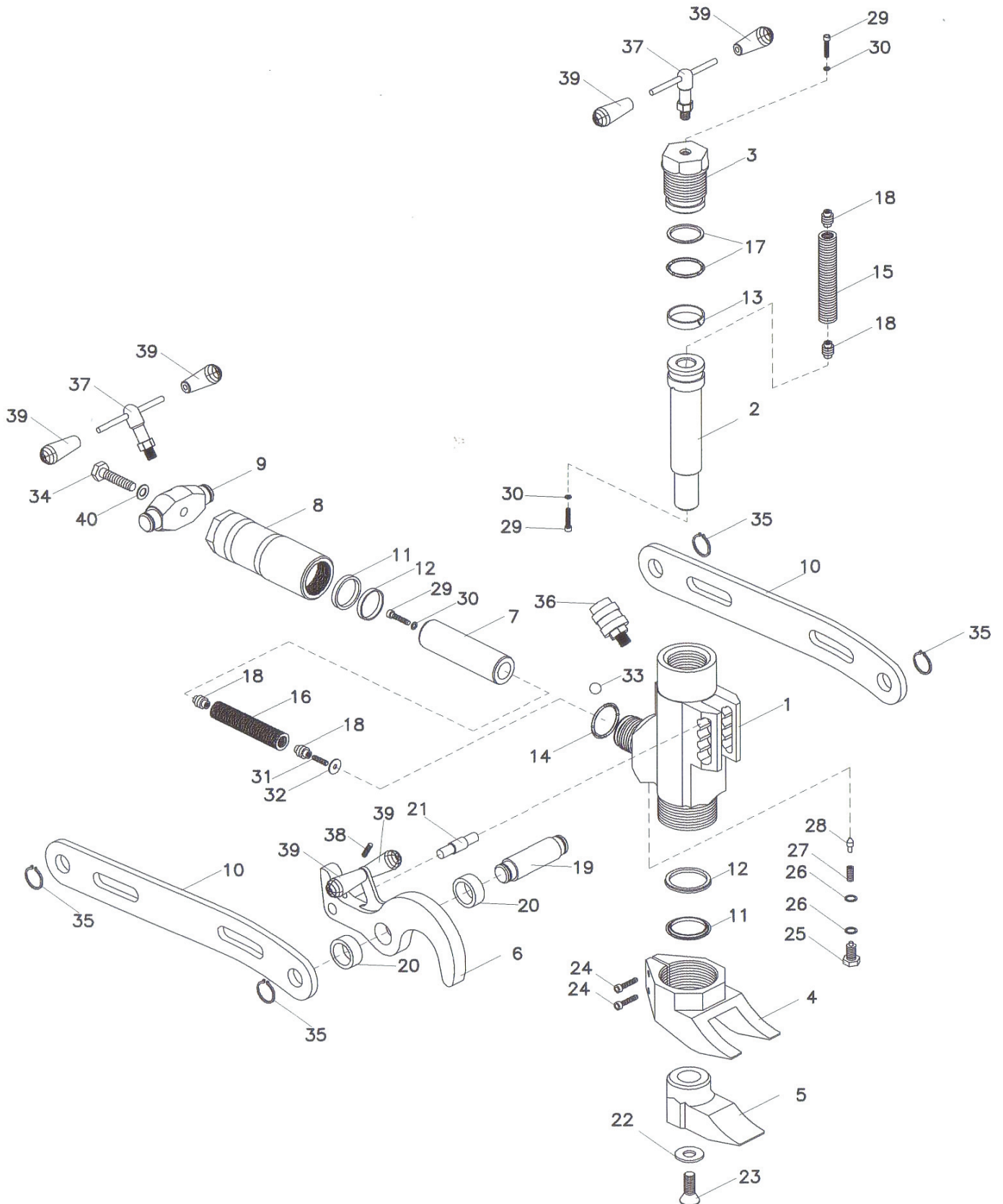



EURO BEAD BREAKER

Model #10107

Parts List

Part #	Description	Qty
1	Body	1
2	Cylinder Rod	1
3	Cylinder Head	1
4	Teeth, Clamping	1
5	Foot	1
6	Clamping, Jaw	1
7	Clamping Cylinder Rod	1
8	Clamping Cylinder Housing	1
9	Rod Base	1
10	Side Strap	2
11	Seal Ring	2
12	Seal Ring	2
13	Seal	1
14	O-Ring	1
15	Spring	1
16	Spring	1
17	O-Ring & Thin Ring	1
18	Nut	4
19	Pin	1
20	Spacers	2
21	Clamp Jaw Pin	1

Part #	Description	Qty
22	Washer	1
23	Screw	1
24	Screw	2
25	Valve Plug	1
26	Washer	2
27	Spring	1
28	Sequencing Ball	1
29	Screw	3
30	Washer	3
31	Screw	1
32	Washer	1
33	Ball	1
34	Bolt	1
35	Snap Ring	4
36	Coupler	1
37	T-Handle	2
38	Set Screw	1
39	Rubber Inserts	6
40	Washer	1
41	Seal Kit	1