

## YAK 44/22 Ton Air Hydraulic HD Jacks



NEW

100%  
MADE IN  
EUROPE

3 YEAR WARRANTY  
**3**  
WARRANTY

- ▶ Air hydraulic jack for heavy vehicles, practical and easy to handle.
- ▶ The pistons move back automatically; the two descent valves guarantee perfect holding in all situations and controlled speed under load.
- ▶ Ideal for workshops, mobile workshops, tire repairers and bodywork shops.

SPECIFICATIONS:

Model Style	92003 YAK 215/N	92004 YAK 221/N
Capacity	44/22 Ton 40/20 Tonne	44/22 Ton 40/20 Tonne
Net Weight	86 lb 39 kg	101 lb 46 kg
Working Air Pressure	116-145 psi 8-10 bar	116-145 psi 8-10 bar
A	55.12" 1400 mm	55.12" 1400 mm
B	51.97" 1320 mm	51.97" 1320 mm
C	20.67" 525 mm	20.67" 525 mm
D	10.63" 270 mm	10.63" 270 mm
E	5.91" 150 mm	8.54" 217 mm
F	3.07" 78 mm	4.96" 126 mm
G	2.83" 72 mm	4.88" 124 mm
H	5.91" 150 mm	9.84" 250 mm
K	8.11" 206 mm	8.11" 206 mm
L	11.81" 300 mm	11.81" 300 mm
M	22 Ton 20 Tonne	22 Ton 20 Tonne
N	44 Ton 40 Tonne	44 Ton 40 Tonne

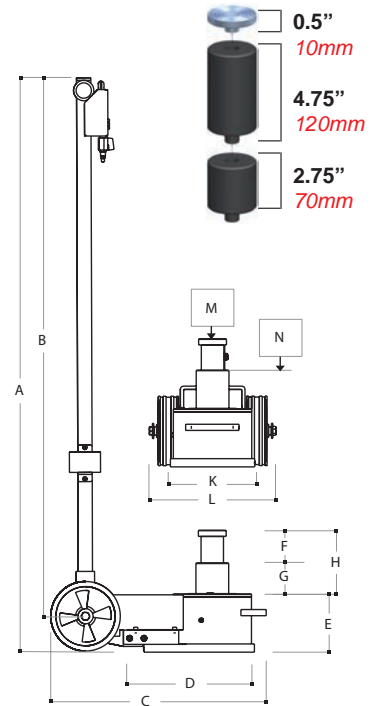

## YAK 44/22 Ton Portable Jack - w/ Removable Handle

Model #92005



NEW

100%  
MADE IN  
EUROPE

3 YEAR WARRANTY  
**3**  
WARRANTY

Air hydraulic jacks for heavy vehicles, lightweight and easy to handle, with removable handle. The pistons move back automatically; the two descent valves guarantee perfect holding in all situations and controlled speed under load. Our portable series par "excellence", all the reliability and practicality of our jacks in a more compact version. Ideal for keeping on board the vehicle and for who provides road assistance. They can work with the vehicles' own compressors. Extensions Includes: 0.5", 4.75", & 2.75"

Model # Style	92005 YAK 217/P
Capacity	44/22 Ton 40/20 Tonne
Net Weight	82 lb 37 kg
Working Air Pressure	116-145 psi 8-10 bar

SPECIFICATIONS:

A	43.31" 1100 mm	E	6.69" 170 mm	K	8.11" 206 mm
B	38.78" 985 mm	F	3.46" 88 mm	L	11.81" 300 mm
C	19.7" 500 mm	G	3.27" 83 mm	M	22 Ton 20 Tonne
D	10.63" 270 mm	H	6.73" 171 mm	N	44 Ton 40 Tonne

